

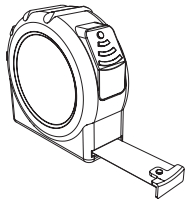

## Martini Soffit – Direct Fix

### Tools you'll need:



Measuring Tape

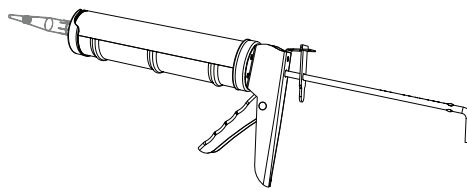

Adhesive

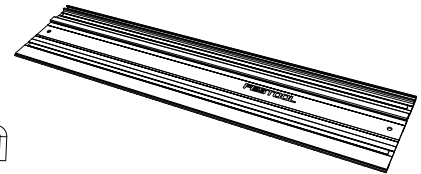

Festool Track & Guide  
with a Granite Blade

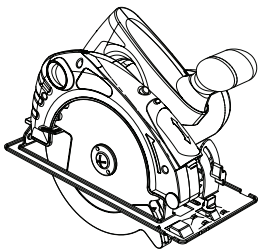

Fine-tooth Blade

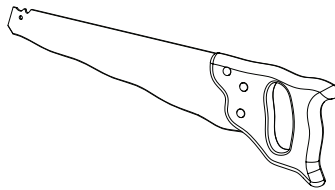

Procut Insulation  
Hand Saw

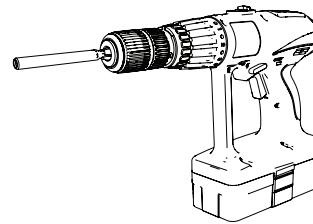

Pin Fastening Tool



Pointed Chisel



Pencil

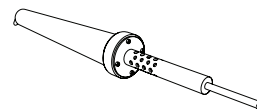

Soldering Iron



Fastening Pin

### Handling and Storage

To ensure unnecessary damage to the sheets we recommend the following:

- Carry bags and sheets upright.
- Avoid unnecessary weights on the sheets.
- Sheets should be kept on a flat clean surface.
- When handling ensure you have clean hands. Alternatively use clean gloves to reduce markings on light colours.

- Store in a cool dry place avoiding humidity.
- Do not stack sheets higher than our recommended quantity below.

Sheet Thickness	Recommended Max Stacked Qty
25mm	50 sheets
50mm	25 sheets
75mm	16 sheets
100mm	8 sheets



## Maintenance - Cleaning

- Remove dust with a light vacuum or duster.
- Remove dirt with a clean soft cloth or sponge.
- Always use a soft damp cloth and blot dry.
- Test a sample first. For more details, refer to CSR Martini Care & Maintenance Guide.

## Installation Considerations

Ensure that you have the planned installation guide from your architect/builder to follow. Always butt join the product in a brick pattern when using Martini Soffit.

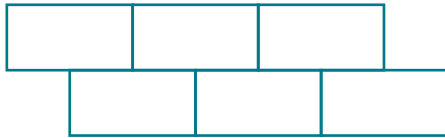

## Cutting Absorb Soffit Sheets

- The recommended cutting method is to use a saw with track and guide with a granite blade, or a procut handsaw.

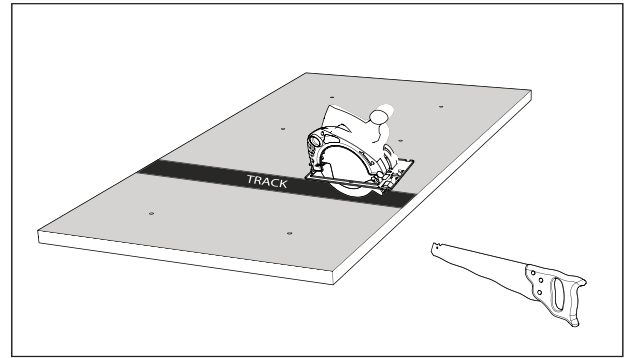

- If using a handsaw, ensure the blade is 90 degrees to the surface for square edges and for best results on butt joints.

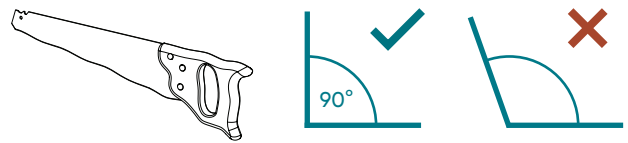

- For best results, use multiple cuts and light pressures.



- Take maximum care for best results.
- Keep flat and use a backing mat.
- Use a secure straight edge for straight cuts.

## Drilling Holes In Martini Soffit

Martini Soffit has a stronger laminated side making ideal for exposed areas.

If you have ordered Martini Soffit with pre-drilled holes, you won't need to action the details below.

### Martini Soffit Pre-drilled Hole Pattern

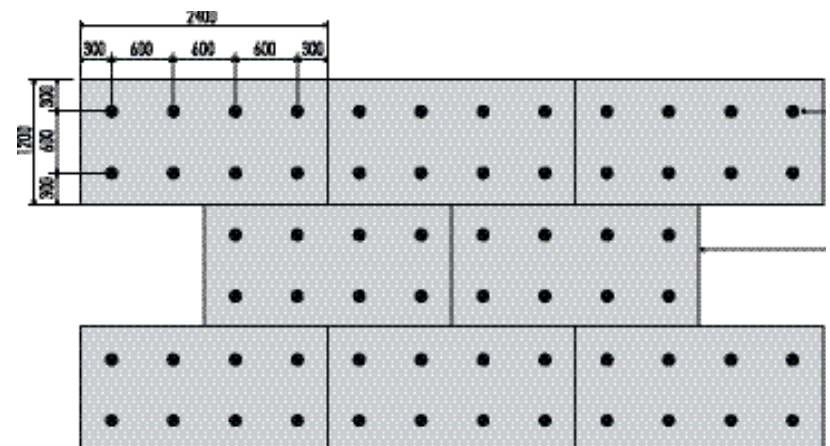

If you have a unique layout and opted to create your own holes, you can use a Leister heat gun that has been modified with copper tube/or a soldering iron. This will successfully melt holes into polyester acoustic products. We recommend creating a template to get accurate holes over the entire installation.

## General Adhesive Applications

- If required, we recommend only applying adhesive on the corners of the Martini Soffit sheets.
- Refer to adhesive manufacturer for preferred application and Installation technique.
- Check supplier data for suitability and perform a test piece to confirm material bond.
- Seal substrates and immediately clean off any spills from the seen surfaces.

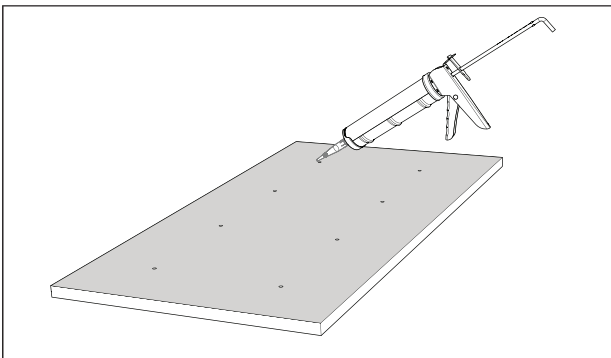

## Managing Obstacles

When applying product around internal services simply cut product (as per cutting guide on previous page) and fit the product around the already installed services.

### OR

If you need to create holes to insert services, you can use a Leister heat gun that has been modified with copper tube/or a soldering iron. This will successfully melt holes into polyester acoustic products.

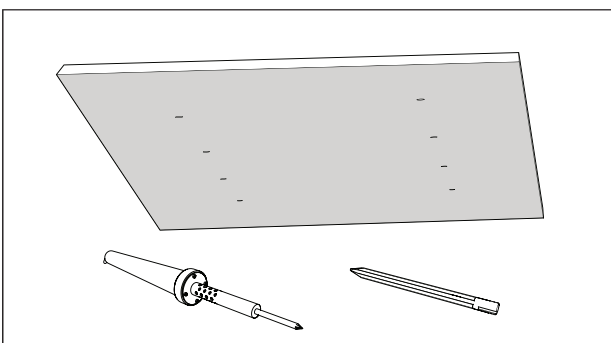

## Before Installing

**NOTE:** Lay out product in natural light to ensure sheets are consistent in colour prior to fixing under soffit.

### Step 1.

If using adhesive's on corners, apply adhesive to the corner of the sheet as per the manufactures instructions/specifications.

### Step 2.

Place sheet in position.

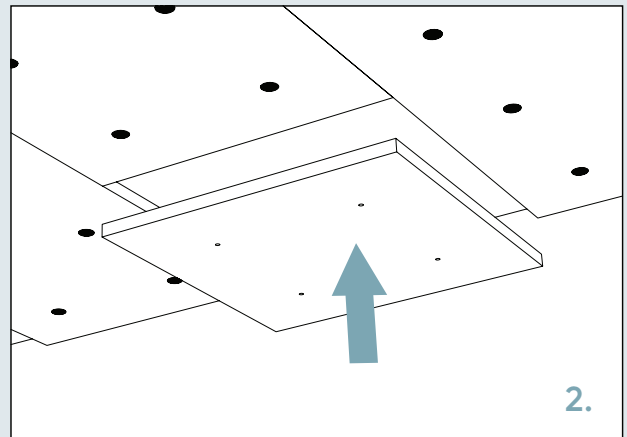

### Step 3.

Using the pin fastener, position the pins through the pre-drilled holes.

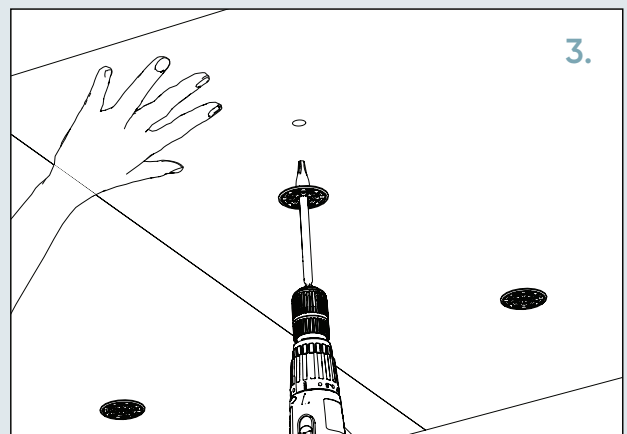

**Step 4.**

Fasten the pin through to secure.

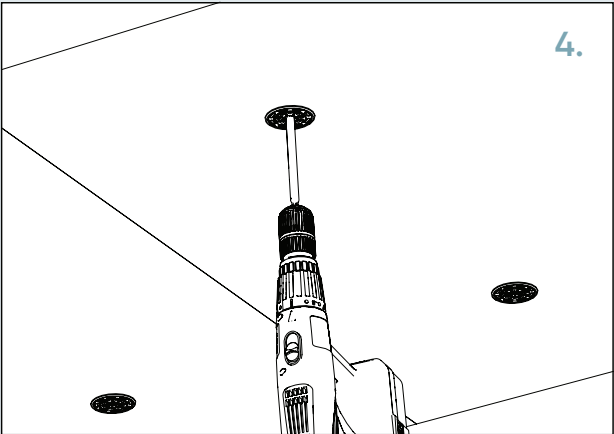

---

**Step 5.**

Repeat steps on all sheets till complete.

