

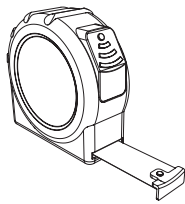

## Martini Absorb

### Tools you'll need:



Measuring Tape

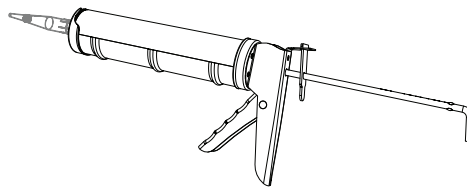

Adhesive

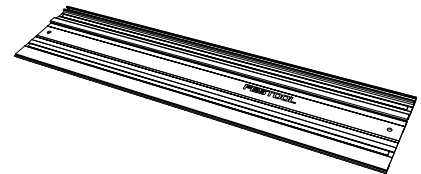

Festool Track & Guide

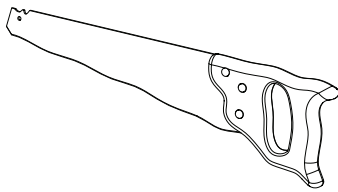

Procut Insulation  
Hand Saw

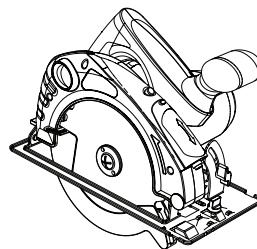

Fine-tooth Blade

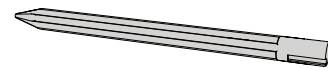

Pointed Chisel



Pencil

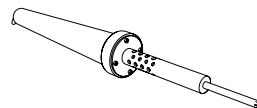

Soldering Iron

### Handling and Storage

To ensure unnecessary damage to the sheets we recommend the following:

- Carry bags and sheets upright.
- Avoid unnecessary weights on the sheets.
- Sheets should be kept on a flat clean surface.
- When handling ensure you have clean hands. Alternatively use clean gloves to reduce markings on light colours.

- Store in a cool dry place avoiding humidity.
- Do not stack sheets higher than our recommended quantity below.

Sheet Thickness	Recommended Max Stacked Qty
25mm	50 sheets
50mm	25 sheets
75mm	16 sheets
100mm	9 sheets



## Maintenance - Cleaning

- Remove dust with a light vacuum or duster.
- Remove dirt with a clean soft cloth or sponge.
- Always use a soft damp cloth and blot dry.
- Test a sample first. For more details, refer to CSR Martini Care & Maintenance Guide.

## Installation Considerations

Ensure that you have the planned installation guide from your architect/builder to follow. Always butt join the product in a brick pattern when using Martini Absorb.

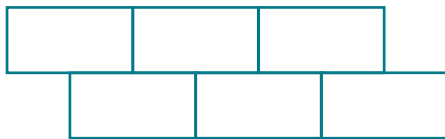

## Cutting Absorb Sheets

- The recommended cutting method is to use a saw with track and guide with a granite blade, or a procut handsaw.

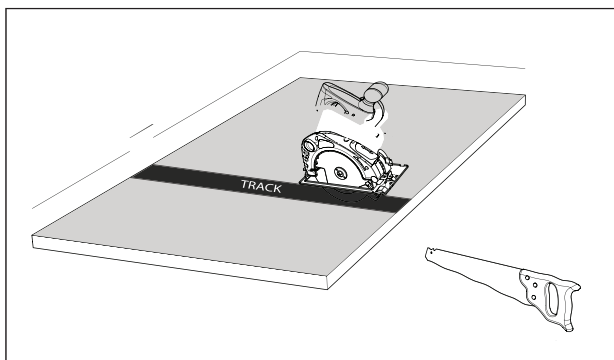

- If using a handsaw, ensure the blade is 90 degrees to the surface for square edges and for best results on butt joints.

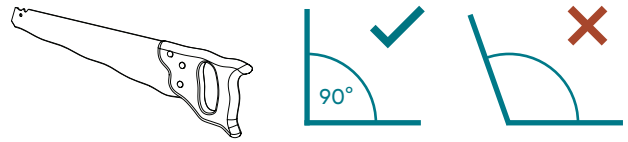

- For best results, use multiple cuts and light pressures.



- Take maximum care for best results.
- Keep flat and use a backing mat.
- Use a secure straight edge for straight cuts.

## General Adhesive Applications

- Refer to adhesive manufacturer for preferred application and Installation technique.
- Check supplier data for suitability and perform a test piece to confirm material bond.
- Seal substrates and immediately clean off any spills from the seen surfaces.
- Press down flat with clean hands to ensure there are no air pockets between the sheet and the surface.

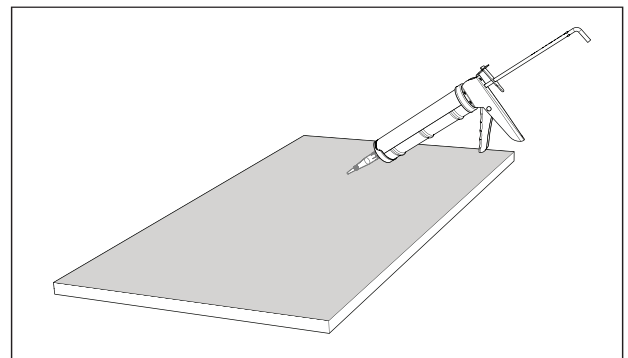

## Managing Obstacles

When applying product around internal services simply cut product (as per cutting guide on previous page) and fit the product around the already installed services.

## OR

If you need to create holes to insert services, you can use a Leister heat gun that has been modified with copper tube/or a soldering iron. This will successfully melt holes into polyester acoustic products.

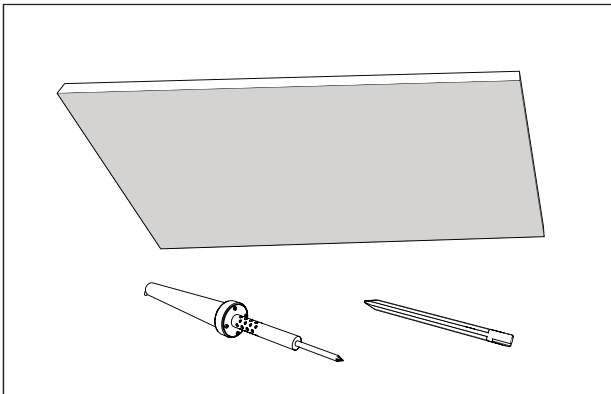

## Installing

### Step 1.

Apply adhesive to the back of the first sheet as per manufactures instructions/specifications.

---

### Step 2.

Place first sheet with edge contact first following with the other half.

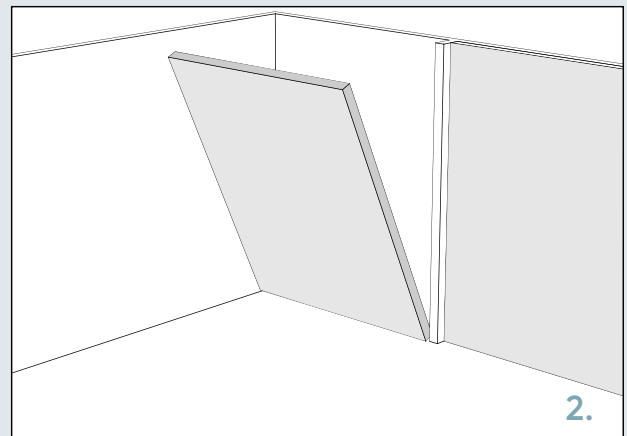

### Step 3.

Ensure you have pressed down firmly with clean hands to avoid air pockets between the surfaces.

---

### Step 4.

Repeat on all sheets till complete. Then fit exposed surface finish i.e. perforated panel.

